

Specifications

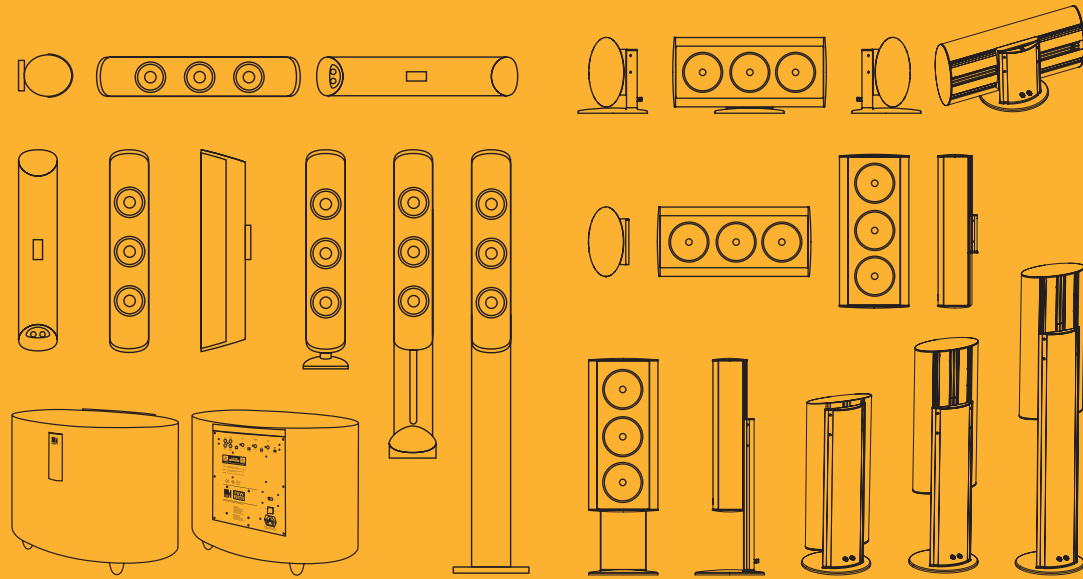

KHT5005

KHT9000

	HTS/HTC5001	PSW2500	KHT9000
Design	Satellite / Centre	Powered subwoofer	Satellite / Centre
Drive units	75 mm (3 in.) Uni-Q array with 15 mm (0.6 in.) HF, 2 x 75 mm (3 in.) LF	Closed box 250 mm (10 in.)	3 way closed box, 165 mm (6 1/2 in.) Uni-Q array with 19 mm (3/4 in.) HF, 2 x 165 mm (6 1/2 in.) LF
Frequency response (± 3dB)	100 Hz - 30 kHz	30 Hz - 150 Hz	75 Hz - 27 kHz
Power handling	100 W	N/A	30 - 150 W
Amplifier	N/A	250 W	N/A
Sensitivity (2.83V/1m)	87 dB	N/A	88 dB
Maximum output (SPL)	104 dB	108 dB	111 dB
Impedance	8 Ω	N/A	8 Ω (min 3.2 Ω)
Internal volume	1.4 litres	15.4 litres	11.5 litres
Weight	2 kg (4.4 lbs)	14.5 kg (31.9 lbs)	9.9 kg (21.8 lbs)
Dimensions (H x W x D)	Satellite 419 x 88 x 127 mm / 16.5 x 3.46 x 5.0 in. Centre	360 x 495 x 325 mm / 14.2 x 19.5 x 12.8 in.	555 x 250 x 125 mm / 21.8 x 9.8 x 4.9 in. 250 x 555 x 125 mm / 9.8 x 21.8 x 4.9 in.
Cabinet finishes	Silver	Silver	Silver



perfect sound wherever you are



Content

KEF and the KHT story	02
Technology Uni-Q®	03
Technology ACE	04
KHT 1005	05
KHT 2005.2	07
KHT 5005	09
KHT 9000 ACE	11
Subwoofers	13
Specifications	14



KEF AUDIO (UK), Eccleston Road, Tovil, Maidstone, Kent, ME15 6QP U.K. Telephone: + 44 (0)1622 672261 Fax: + 44 (0)1622 750653
 US DISTRIBUTOR: KEF America, 10 Timber Lane, Marlboro, New Jersey 07746 U.S.A. Telephone: +(1) 732 683 2356 Fax: +(1) 732 683 2358 www.kefamerica.com
 KEF and Uni-Q are registered trademarks. Uni-Q is protected under GB patent 2 236929 and U.S. Pat. No. 5,548,657. Worldwide patents pending. KEF reserve the right, in line with continuing research and development, to amend or change specifications. The photographs in this catalogue show speakers in various finishes some of which may not be available in your territory. This catalogue is printed using chlorine-free materials and is fully recyclable.

KEF and the KHT story

The more sophisticated that digital audio formats become, the better your speakers need to be. Which to choose, though? Manufacturers come and go. Design trends appear, then fade away. But with KEF, you're dealing with people who've been consistently innovating since 1961.

The KEF Home Theatre (KHT) series is a good example. By bringing audiophile quality sound to affordable home entertainment, it's been breaking new ground ever since it was first introduced. As its many awards and 5-star ratings prove, the original outperformed every conventional system in its class.

But the latest KHT systems extend this advantage even further, whatever your budget. With the introduction of radically innovative concepts like Acoustic Compliance

Enhancement (ACE), the latest refinements of KEF's trademark Uni-Q technology and a new generation of powered subwoofers, there's a formidable line-up of options to choose from. They're all designed to reproduce every last detail encoded in the latest home entertainment formats, and having identical drivers for the satellite and centre speakers of each system guarantees a perfect tonal match. Naturally, they're all magnetically shielded to avoid interference with your other equipment. And although each has its own distinctive look, every system is engineered with acoustically inert cast aluminium enclosures and high end components including new metal dome tweeters to create an accurate and compellingly real 3D soundscape - and with the ultra-wide dispersion characteristics of KEF's Uni-Q point source array, it's enjoyed with equal pleasure by everyone in the room.

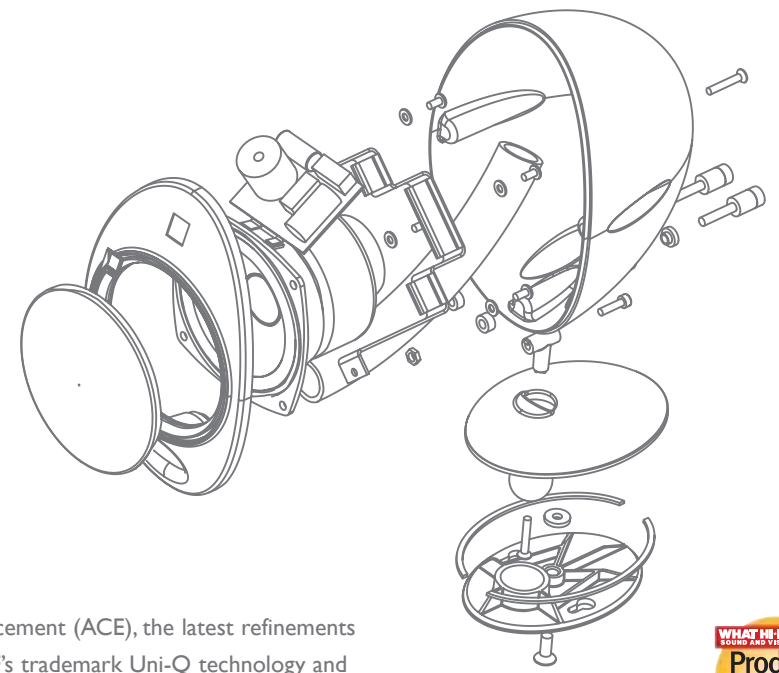

Technology

Uni-Q

KEF's patented Uni-Q driver configuration disperses the sound image over a much larger area than a conventional speaker, instead of being restricted to a small 'sweet spot'. This outstanding off-axis response is made possible by using aerospace materials to engineer a high performance tweeter that's small enough to mount in the exact acoustic centre of the bass/midrange cone so that both act as a single point source – an ideal that so far, only KEF has achieved.

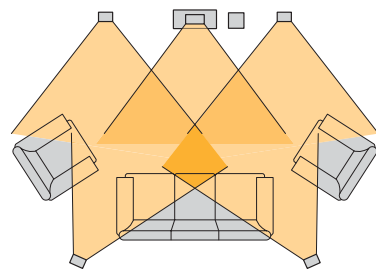

Conventional loudspeaker dispersion showing narrow 'sweet spot'

Based on those developed for the legendary Reference Series, the Uni-Q arrays in the new KHT range are the most sophisticated yet, with new metal dome HF drivers that reproduce the human voice with breathtaking accuracy. In purely practical terms, the larger sound image gives you far greater flexibility in placing your speakers where they look best. For home theatre, it means that you experience even the subtlest 3D soundtrack effects with the same clarity and realism wherever you sit.

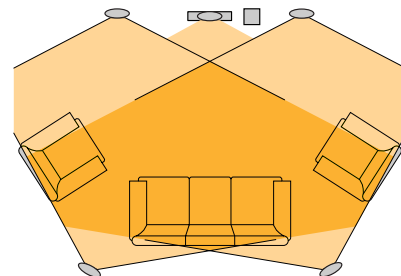

Excellent dispersion characteristics common with all Uni-Q based products showing wider listening area

ACE

The holy grail of loudspeaker design has always been to generate big bass from small boxes. The trouble is, the laws of physics make this almost impossible to achieve, as bass extension relates directly to efficiency and cabinet size. Continuing a 40-year tradition of genuine design innovation, KEF engineers have now developed a way of overcoming this apparently insoluble limitation. It's called Acoustic Compliance Enhancement (ACE), and it works like this. In conventional speakers, cone motion is restricted by the acoustic pressure in the enclosure as the air is alternately compressed and expanded by the cone moving in and out. The smaller the enclosure, the greater the pressure that acts on the cone. By dramatically reducing this pressure, ACE allows the cone to move as freely as it would in a much larger cabinet, generating bass extension out of all proportion to its actual size.

This is achieved by introducing granules of activated carbon into the enclosure – a material containing millions of pores ranging in size from visible fissures to holes a few molecules across. One of its characteristics is a capacity for physical adsorption, the gravity-like molecular force in which a substance (usually a gas) accumulates in a thin film on the surface of a solid. In the ACE loudspeaker when the cone moves inwards the air pressure increases, triggering adsorption of air molecules from the free air into the carbon. This removal of air molecules from the free air causes the internal pressure to decrease. When the cone moves outwards the opposite happens and the carbon gives out air molecules. The ACE material is constantly acting to reduce the pressure variations in the enclosure in a controlled and linear fashion.

Effect of ACE on a 10 litre closed box loudspeaker

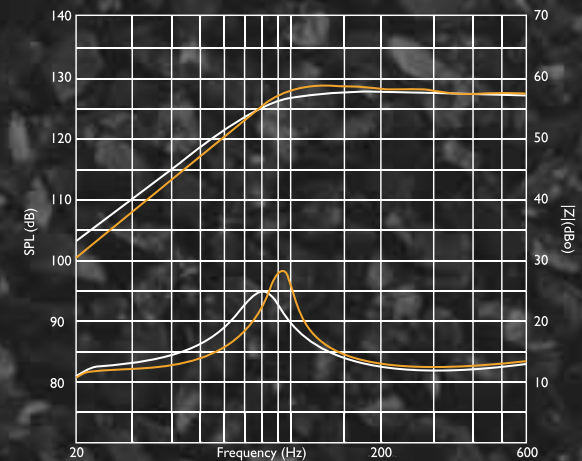

It's an innovation that makes an amazing difference for the listener. By enhancing compliance by anything from 150% to 300%, ACE-enabled loudspeakers perform like units up to three times their size. In trials of identical Uni-Q arrays fitted to an ACE enclosure 40% smaller than the test cabinet, not only did the listeners agree that bass was undiminished - they unanimously preferred the bass attack of the ACE version. And that's the acid test of any radical breakthrough in audio design: subjectively as well as objectively, ACE enriches the listening experience.



"The sound & music are 50% of the entertainment in a movie."

George Lucas

KHT 1005

They may look cute - but they sound anything but. Experiencing a movie or favourite album through KHT 1005 is like seeing an old friend after a makeover: fresh, involving, more intense. The centre and satellite speakers all have KEF's stunning new 75 mm (3") Uni-Q driver - the smallest ever made, its 15 mm (0.6") metal dome tweeter and double neodymium magnets delivering the extended bandwidth you normally get with much larger units.

The curvy die-cast aluminium enclosures eliminate the diffractions and internal resonances that so often blur the output of conventional small speakers, so the sound is cleaner and crisper. The sound image is completed by the new slot-ported PSW1000.2 subwoofer, its 100-watt onboard power amp driving a 200 mm (8") long throw down-firing bass unit. With output fully adjustable for phase, frequency and level, a ground lift to prevent

hum and a cinema setting for even weightier bass punch, its attack is as forceful as it is accurate. Whether you prefer shelf mounting, optional wall brackets or floor stands with internal cable management, the installation is as discreet as can be - until you press 'play', and the whole room fills with immaculate three-dimensional sound. Matt silver finish.



Discreet design



Smallest ever Uni-Q array 75 mm (3") with 15 mm (0.6") aluminium dome tweeter (top)
Cast aluminium enclosure (bottom)



Optional floor stands



KHT 2005.2

Charismatic is the only word to describe it. Like the multi-award-winning KHT 2005 from which it evolved, the new reflex-ported KHT 2005.2 pushes the performance envelope of midrange home theatre like no other system. The spec tells part of the story: with parabolic enclosures computer optimised to eliminate cabinet distortions, the full range centre and satellites all feature KEF's new 100 mm (4") Uni-Q array incorporating the 19 mm (3/4") aluminium dome tweeter from the acclaimed Q series.

Ferrofluid cooled for better power handling and driven by twin neodymium magnets, HF reproduction is startling – even whispered dialogue is pin-sharp. But the real magic lies in the way all the system components work together. The tonal match is perfect, and transitions are so smooth you simply can't hear them. Like all KHT series subwoofers, the matching 250-watt PSW2010 has a cinema setting for even more bass 'slam' with movie sound effects, and individual phase,

frequency and level controls allow you to fine tune the output to get the perfect balance with the satellite speakers and your room acoustics. An ingenious multi-directional base makes it easy to place each satellite wherever it suits you: on a flat surface, at an angle on walls, or on the optional floor stands. It all adds up to a chic, superbly engineered system that delivers way beyond what you'd expect for the price. Available in matt silver finish or soft black.



"Wait a minute, wait a minute.
You ain't heard nothing yet!"

Al Jolson 1886 - 1950
The Jazz Singer, October 6th 1927



PSW2010 active subwoofer



Cable management system built into mounting bracket (top) Soft black finish (bottom)



100 mm (4") Uni-Q driver with twin neodymium magnet system and 19 mm (3/4") aluminium dome tweeter (top) Adjustable stand (bottom)





KHT 5005

The cool minimalism of these slender cast aluminium column speakers belies the sophistication of the technology that makes them sound so authoritative. Flanked by a pair of 75 mm (3") long throw bass drivers with ultra-low distortion motor systems, the Uni-Q array has KEF's 15 mm (0.6") metal dome HF driver at the acoustic centre of the 75 mm (3") midrange cone to disperse a seamless sonic image evenly throughout the listening area. And what an image it is - richly textured and spatially precise in every dimension.

Whether you're watching a film or chilling out to a few tracks, they sound as clean as they look. KEF's characteristic attention to detail in everything from the audiophile grade wiring and internal components to the curvature of the cabinets maximises the Uni-Q performance advantage, creating a big, expansive sound that's accurate enough to clarify every nuance in the recording. The sensational new elliptical PSW 2500 subwoofer for KHT 5005 is a closed box design with a 250 mm (10") long-throw driver that pumps out a genuine 250 watts of

distortion-free bass. Individually adjustable phase, frequency and level controls (with 12dB/24dB variable slope switching) allow you to fine tune the output to your personal preferences and the acoustics of the room - and with the choice of floor stands, wall brackets and either short or infinitely adjustable height desk stands, you can place the satellite speakers wherever they look best. Matt silver finish.



"It's always the best policy to allow the film to speak for itself."

Stanley Kubrick 1928 - 1999



3 Way, closed box design 75 mm (3") Uni-Q driver and bass units Die-cast aluminium enclosure



PSW 2500 subwoofer (top) Rear panel controls (bottom)

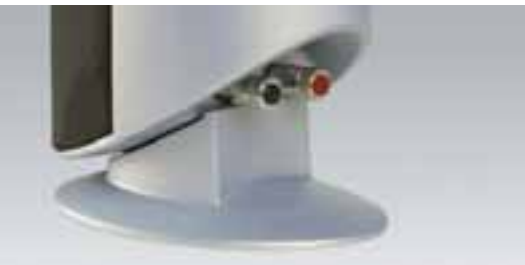

Wall or Table top mounting options



KHT 9000 ACE

As the flagship system of the KHT family, KHT 9000 ACE combines KEF's latest performance enhancing innovation with an uncompromised technical specification to create a true audiophile quality 3D sound picture: incredibly spacious, intricately detailed and totally engrossing. The 165 mm (6 1/2") Uni-Q driver array brings out the full emotional depth and texture of vocals, whether sung, shouted, spoken or whispered – hardly surprising, since it's exactly the same unit as you'll find on the high end Q and XQ series. On either side, a matching pair of long throw bass drivers with

ultra-low distortion motors for low frequency response that's as lucid as it is gutsy - and thanks to KEF's Acoustic Compliance Enhancement, what you actually hear is the level of bass extension that's only normally obtainable with much larger speakers. To achieve a genuinely integrated look that complements modern interiors, you have the option of wall brackets or infinitely adjustable desk or floor stands with stand-mounted terminals connecting to the drivers via an ingenious sliding track system. Depending on the mounting system chosen, stand or wall

bracket, the connections automatically select either the free space or wall mount response setting. The wall filter has a unique form which corrects for both the fundamental wall reflection below 200Hz and the second mode at 700Hz allowing unprecedented tonal accuracy for a wall mounted speaker. Available separately, and with a choice of compatible powered subwoofers, you're free to tailor yourself the set-up that best suits your tastes. If you take your entertainment seriously, it's a blue chip investment in pure pleasure.



"Who the hell wants to hear actors talk?"

H. M. Warner, Warner Brothers, 1927



Aluminium baffle 165 mm (6 1/2") Uni-Q driver from XQ Series 2 x 165 mm (6 1/2") woofers



ACE technology for improved bass (top) Crossover (bottom)



Innovative short/tall sliding stands Wall/Free-space balance options

Subwoofers



Your choice of subwoofer for the KHT 9000 system depends more on your personal preferences than the size of your listening area, as both are more than capable of filling even the largest room with sound. The on-board power amp on the PSW3000 delivers a genuine 300 watts, driving a large 250 mm (10") high performance long throw bass unit. With audiophile grade internal components and output, phase and low pass filter frequency fully adjustable via RF remote control,

it anchors the 3D soundscape in a bass presence whose depth and clarity you feel in your body as much as your ears. Alternatively, consider the PSW4000, one of the finest subwoofers you can buy anywhere, at any price. No less than 500 watts of high efficiency Class D amplifier power, with a 300 mm (12") long throw driver in a wood cabinet finished by hand to fine furniture standards. In terms of sheer bass extension it's quite awesome, of course - but what's

even more impressive is how tightly the response is controlled. For a speaker that can generate such an overwhelming tidal wave of sound, it has astonishing delicacy – you find yourself enjoying details in the sound image you never even knew existed. If you're in pursuit of the ultimate, look no further.

For detailed specifications visit www.kef.com.

KHT Subwoofer Rear Panel

1. Line in input sockets
2. High pass output sockets
3. Ground In / Out
4. Level control
5. Music / Cinema
6. Crossover Frequency control
7. Slope
8. Phase control
9. Mains indicator light
10. Auto/manual switch

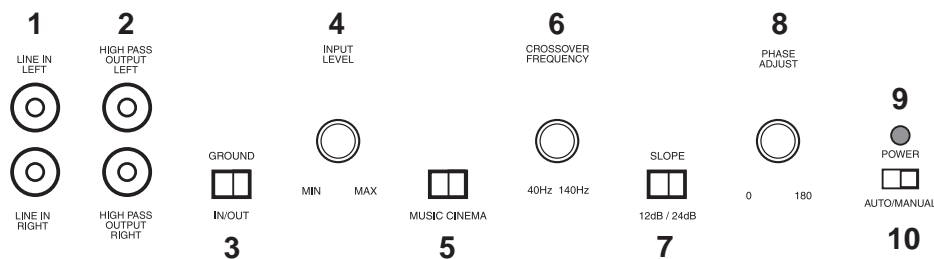

Specifications

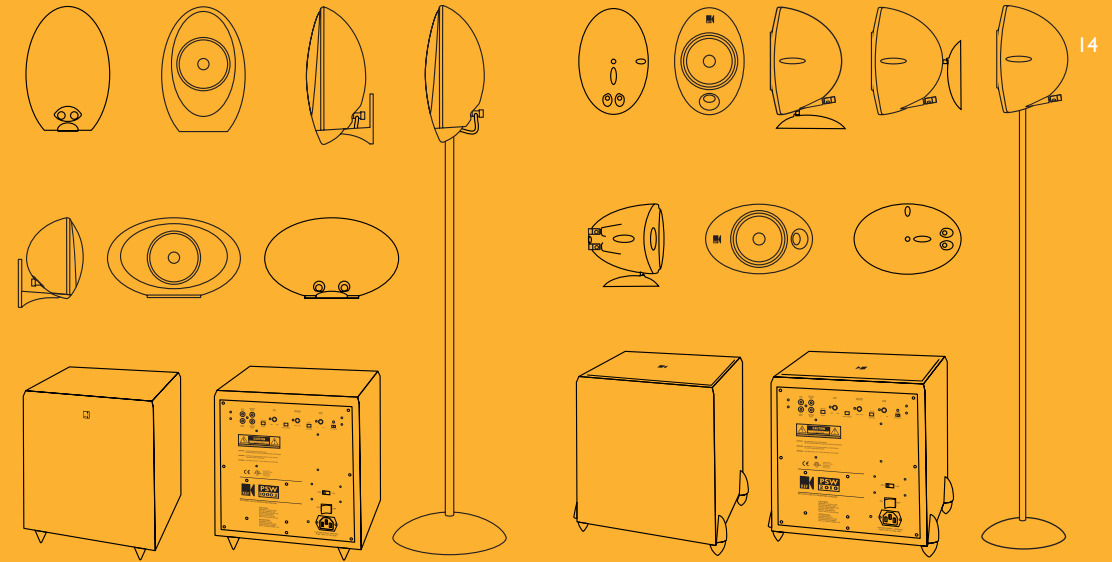

KHT1005

KHT2005.2

	HTS/HTC1001	PSW1000.2	HTS2001.2	PSW2010
Design	Satellite / Centre	Powered subwoofer	Satellite / Centre	Powered subwoofer
Drive units	Closed box 75 mm (3 in.) Uni-Q array with 15 mm (0.6 in.) HF	Bass reflex 200 mm (8 in.)	Reflex ported 100 mm (4 in.) Uni-Q array with 19 mm (3/4 in.) HF	Closed box 250 mm (10 in.)
Frequency response (± 3 dB)	120 Hz - 30 kHz	38 Hz - 180 Hz	80 Hz - 27 kHz	30 Hz - 150 Hz
Power handling	100 W	N/A	100 W	N/A
Amplifier	N/A	100 W	N/A	250 W
Sensitivity (2.83V/1m)	86 dB	N/A	88 dB	N/A
Maximum output (SPL)	104 dB	106 dB	104 dB	108 dB
Impedance	8 Ω	N/A	8 Ω	N/A
Internal volume	0.5 litre	15.4 litres	1.5 litres	15.4 litres
Weight	1 kg (2.2 lbs)	13.5 kg (29.7 lbs)	2 kg (4.4 lbs)	14.5 kg (31.9 lbs)
Dimensions (H x W x D)	Satellite 165 x 110 x 78 mm / 6.5 x 4.4 x 3.1 in.	360 x 320 x 320 mm / 14.2 x 12.6 x 12.6 in.	198 x 130 x 150 mm / 7.8 x 5.1 x 5.9 in.	360 x 320 x 320 mm / 14.2 x 12.6 x 12.6 in.
Cabinet finishes	Silver	Silver	Silver, Soft Black	Silver, Black